

SUD

MARCIAPIEDE

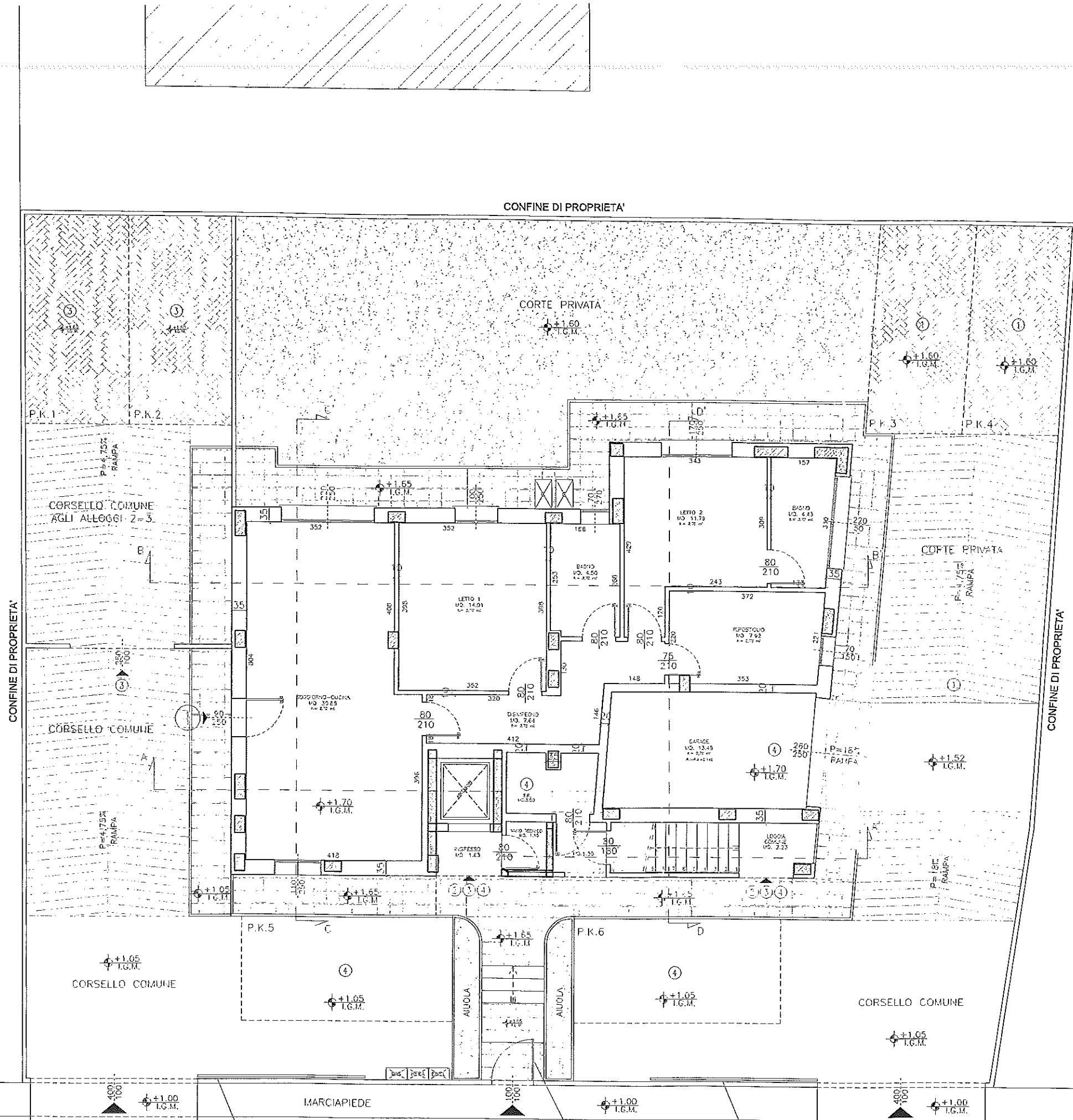

CONFINI DI PROPRIETA'

CONFINI DI PROPRIETA'

CORSELLO COMUNE  
AGLI ALLOGGI 2-3

CORSELLO COMUNE

CORSELLO COMUNE

CORSELLO COMUNE

CONFINI DI PROPRIETA'

CORTE PRIVATA

CORTE PRIVATA

FABBRICATO  
NORD

INGRESSO CARRAIO

CANCELLO SCORREVOLE  
AUTOMATICO

INGRESSO PEDONALE

CANCELLO AD 1 ANTA  
PEDONALE

CANCELLO SCORREVOLE  
AUTOMATICO

VIA GARIBALDI

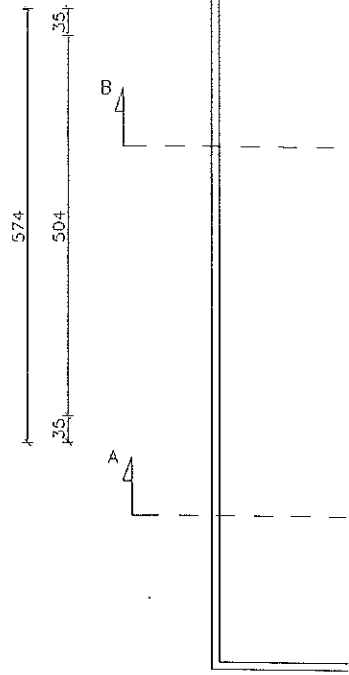
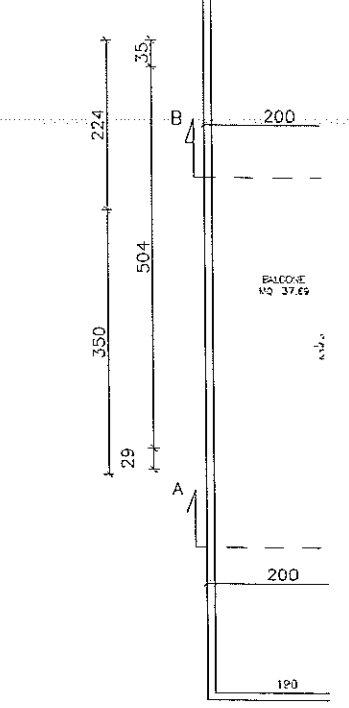

+0.20  
T.C.M.

+1.00  
T.C.M.

+1.05  
T.C.M.

+1.65  
T.C.M.

+1.70  
T.C.M.

+1.05  
T.C.M.

+1.65  
T.C.M.

+1.05  
T.C.M.

+1.55  
T.C.M.

+1.70  
T.C.M.

+1.05  
T.C.M.

+1.52  
T.C.M.

+1.00  
T.C.M.

+1.00  
T.C.M.

+0.20  
T.C.M.

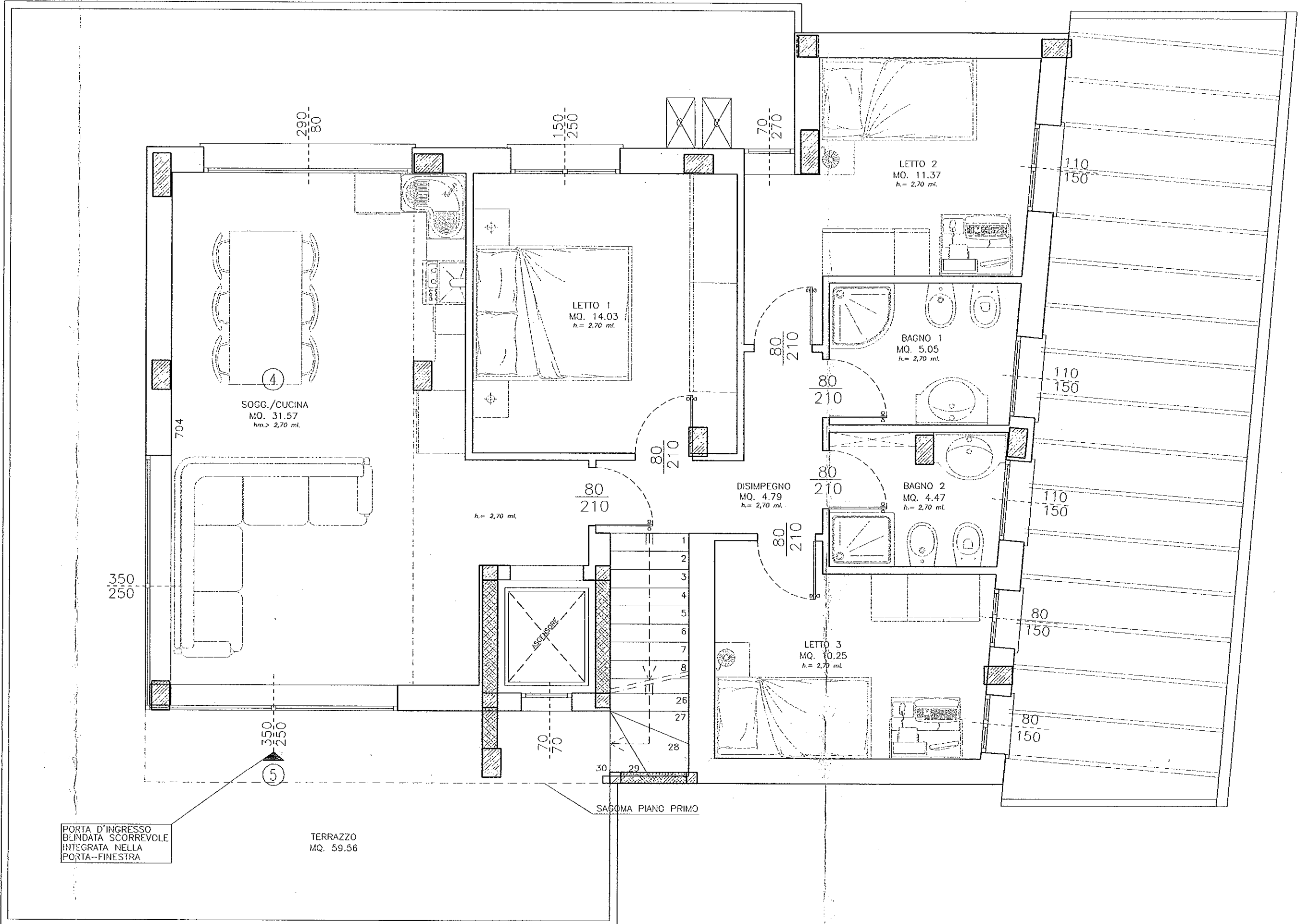

290  
80

150  
250

70  
270

LETTO 2  
MQ. 11.37  
h. = 2,70 mt.

110  
150

LETTO 1  
MQ. 14.03  
h. = 2,70 mt.

BAGNO 1  
MQ. 5.05  
h. = 2,70 mt.

110  
150

SOGG./CUCINA  
MQ. 31.57  
hm. > 2,70 mt.

BAGNO 2  
MQ. 4.47  
h. = 2,70 mt.

110  
150

DISIMPEGNO  
MQ. 4.79  
h. = 2,70 mt.

LETTO 3  
MQ. 10.25  
h. = 2,70 mt.

80  
150

80  
150

ASCENSORE

80  
210

80  
210

h. = 2,70 mt.

350  
250

350  
250

70  
70

30

29

SAGOMA PIANO PRIMO

PORTA D'INGRESSO  
BLINDATA SCORREVOLE  
INTEGRATA NELLA  
PORTA-FINESTRA

TERRAZZO  
MQ. 59.56